

Electronic pump control ENP

Electronic single/dual pump control with monitoring features

Electronic pump control for filling and emptying a tank with integrated relative pressure transducer for panel board mounting, connection for pneumatic tube, four adjustable switching points, three relay outputs, staging and sequencing control, isolating transformer acc. to VDE 0550.

Function: The device analyses the pressure applied to the sensor. Two pumps for emptying a tank are connected to terminals 11/14 and 21/24 on alarm can be connected to terminals 31/34.

All levels are adjustable. The LED's illuminate when the pumps or the alarm are switched on. The relays are activated. The tripping delay for the alarm is fixed, preset value.

Wiring diagrams ENP

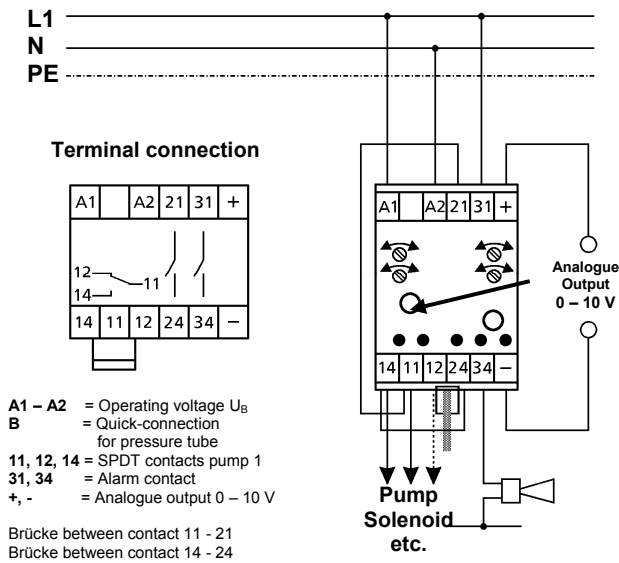

ENP as single-pump control

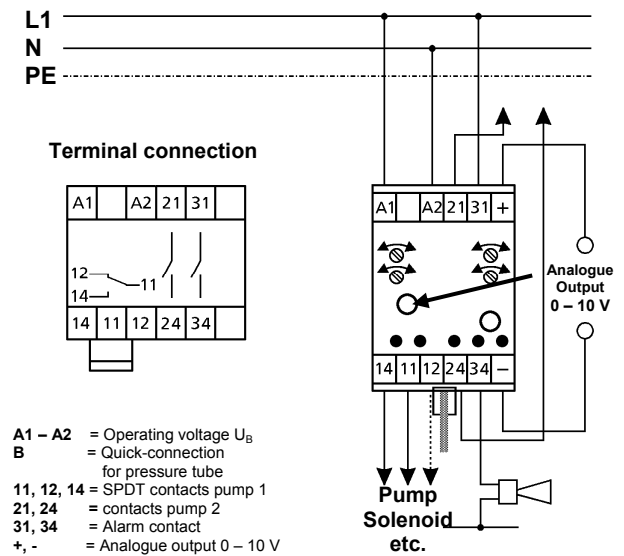

ENP as dual-pump control

Technical Data ENR

Technical operating data	
Permissible operating voltage range	230
Operating voltage influence at $\pm 10\%$ operating voltage fluctuation	$\pm 10\%$
Duty factor ED	$< 0,1\%$
Permissible ambient and media temperature	100 %
Permissible ambient humidity to rel. humidity, non-condensing	-20°C up to $+60^{\circ}\text{C}$
Permissible storage temperature	10 % bis 90 %
Clearance and creepage distances	-40°C up to 80°C
Working position	VDE 0110
Power consumption	any position
Permissible operating voltage range	max. 1,5 VA
Measuring range (m) depending on type ENP 2,3, 4,3 u, 10,3	0,1-2m, 0,1 - 4 m 0,1 - 10 m
Max. inaccuracy at 25°C	2,5 %
Resolution depending on type ENP 2,3, 4,3 u, 10,3	0,01 m, 0,01 m 0,10 m
Max. perm. level (m) depending on type ENP 2,3, 4,3 u, 10,3	10 m, 10 m, 20 m

Enclosure	
Material	RABS flameproof, UL-approved
Mounting	snap on 35 mm DIN-rail connector acc. to EN 50 035
Enclosure protection	IP 40
Protection against shock	Acc. VBG 4
Terminals	Cage clamps
Cross section	2,5 mm ²
Weight	290 g
Male jack plug Jack 2.5 mm	2,5 mm

Power section	
Series voltage acc. to VDE 0660 and VDE 0110 Group C	250 V-AC
Maximum continuous current per contact	6 A-AC
Maximum switching capacity per contact	1.500 VA (AC) 50 W (DC)
Mechanical life Cycles	approx. 1×10^7
Electrical life (max. load) Cycles	approx. 1×10^5

Pressure connection	
Quick connect suitable pneumatic tube e.g.	6 x 1 mm Festo PAN

Analogue output	
Analogue voltage signal max. 5 mA short-circuit proof	0 - 10 V

Assembly and Adjustment for the 1-pump control

The connection, commissioning and maintenance of the electronic pump control must be under the guidance of appropriate personnel. Please note that for the construction and commissioning of electrical equipment relevant prevailing standards.



1.) During single pump operation, it is of the utmost importance to add a bridge from contact 11 to contact 21 and from contact 14 to contact 24.

Load fluctuations become ineffective and the operation of single pump control is guaranteed. The analogue output set point S3 (peak load) is disabled.



2.) For the correct function of the measurement system in the tightness of the connection significantly. Therefore, the tube must be cut straight and may not have scratches at the end. The tube must be inserted fully into the connector. Thereby unplug the ring! It should be noted that the tube has to be pushed over the first resistance of the plug connection. Only then the tube is completely connected.

3.) A closed wet bell with adequate volume must be attached to the measuring end if the system is operated as a closed measuring system. The following volumes are acceptable:

Pneumatic tube length: 5 m ► Volume 0.5 l Pneumatic tube length: 20 m ► Volume 1.5 l

This will ensure a fully operational measuring system.

If the system is operated as an open measuring system, i.e. with an open wet ball, a suitable aeration or bubbler operation is recommended.

4.) If the system is operated with a suitable submersible bell instead of a bubbler system, it is advisable that the following be performed once a year:

a) Lower the fluid level below that of the bell, i.e. by activating the sip mode,

b) Pull the pneumatic tube together with the wet ball completely out of the fluid and submerge again.

5.) Recommended tube Festo PAN 6 x 1

Configuration instructions

The device must be switched to test mode for configuration purposes. This can be achieved by pressing the "TEST" key for 2 seconds. The device indicates that it is in test mode optically, by flashing the green test-LED. The 3 LEDs, N1, P+ and AL, now indicate whether the current fluid level lies above or below the corresponding switching thresholds (LED lights up → indicates that fluid level lies above the configured switching threshold). The thresholds can be set higher or lower by turning the corresponding knobs (higher in a clockwise direction, lower in an anticlockwise direction). After configuring the set point tolerances, exit test mode by pressing the "TEST" key once again. The configured values are now stored.

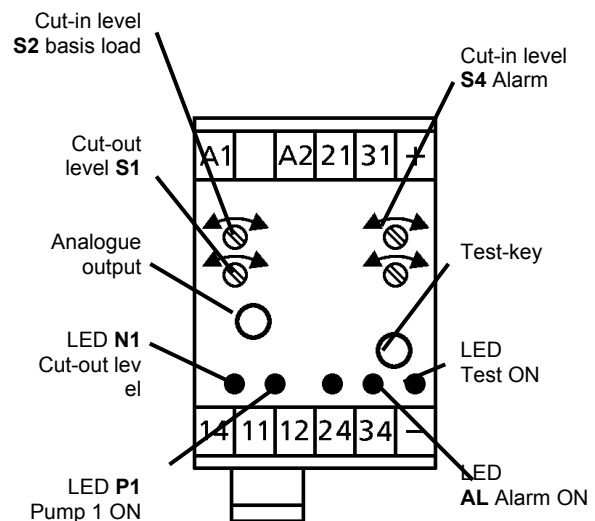

Analogue output and LED assignment in test mode:

a) Cut-out level	Poti S1	LED N1 (green)
b) Basis load level	Poti S2	LED P1 (red)
c) Alarm level	Poti S4	LED AL (red)

- Example:**
- press the "TEST" key for 2 seconds → the device is now in test mode
 - set the desired shut-off level
 - LED **N1** on → turn the analogue output knob **S1** clockwise until the LED turns off
 - LED **N1** of → turn the analogue output knob **S1** anticlockwise until the LED turns on
 - adjust the base load level as desired
 - LED **P1** on → turn the analogue output knob **S2** clockwise until the LED turns off
 - LED **P1** off → turn the analogue output knob **S2** anticlockwise until the LED turns on
 - adjust the alarm level as desired
 - LED **AL** on → turn the analogue output knob **S4** clockwise until the LED turns off
 - LED **AL** of → turn the analogue output knob **S4** anticlockwise until the LED turns on
 - press the "TEST" key to exit the test mode

Function example 1-pump control

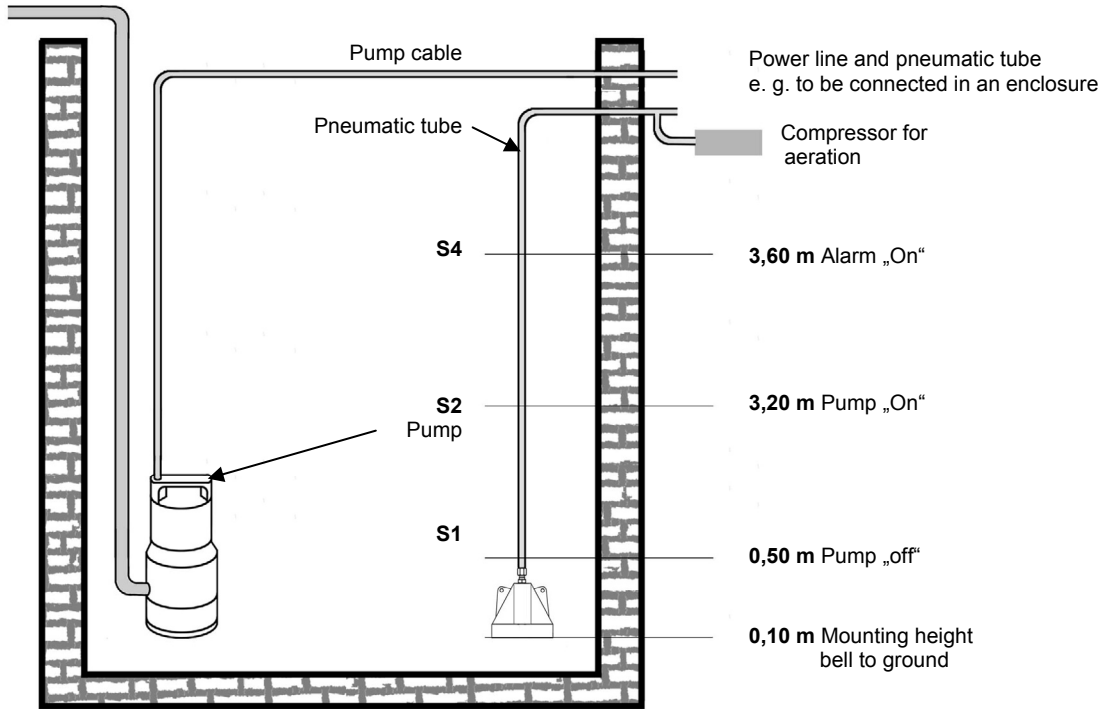

The levels specified here have been chosen arbitrarily and serve as examples (ENP 4,3). The corresponding measurement range and maximum permissible fluid level of the corresponding type ENP should be taken into account when values are set for each respective set point (S1, S2, and S4).

Pump control	ENP 2.3	Measuring range	0,1 – 2 m	max. perm. level	10 m
Pump control	ENP 4.3	Measuring range	0,1 – 4 m	max. perm. level	10 m
Pump control	ENP 10.3	Measuring range	0,1 – 10 m	max. perm. level	20 m

Functional sequence 1-pump control

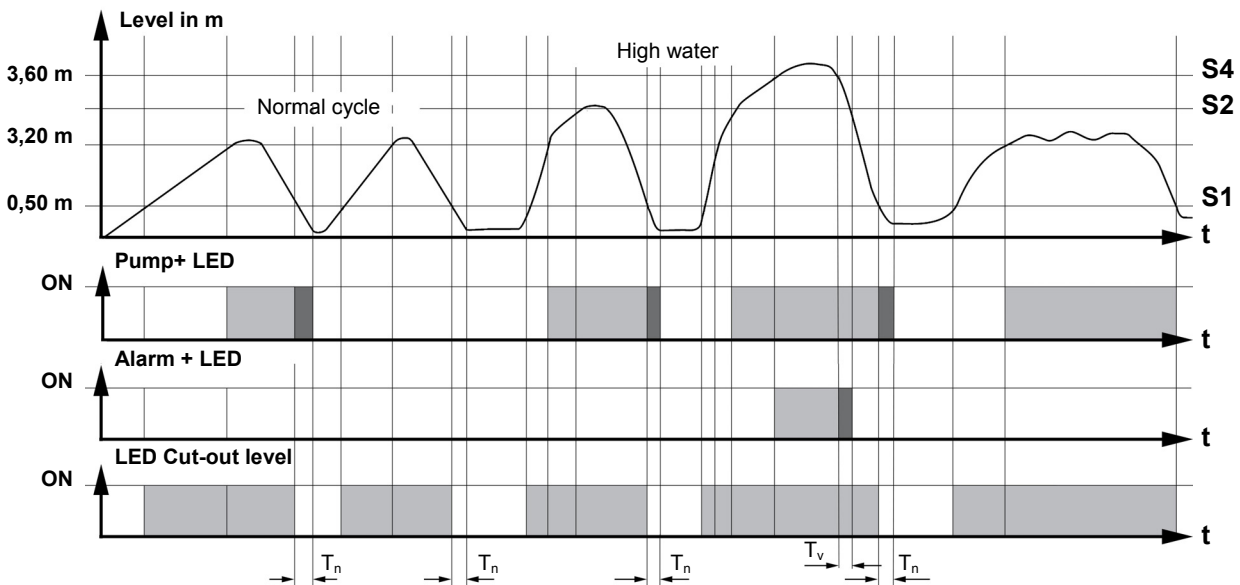

T_v = Switching off delay "Alarm"
 T_n = Follow-up time Pump

Assembly and Adjustment for the 2-pump control

The connection, commissioning and maintenance of the electronic pump control must be under the guidance of appropriate personnel. Please note that for the construction and commissioning of electrical equipment relevant prevailing standards.



- 1.) For the correct function of the measurement system in the tightness of the connection significantly. Therefore, the tube must be cut straight and may not have scratches at the end. The tube must be inserted fully into the connector. Thereby unplug the ring! It should be noted that the tube has to be pushed over the first resistance of the plug connection. Only then the tube is completely connected.
- 2.) A closed wet bell with adequate volume must be attached to the measuring end if the system is operated as a closed measuring system. The following volumes are acceptable:
Pneumatic tube length: 5 m ► Volume 0.5 l
Pneumatic tube length: 20 m ► Volume 1.5 l
This will ensure a fully operational measuring system.
If the system is operated as an open measuring system, i.e. with an open wet ball, a suitable aeration or bubbler operation is recommended.
- 3.) If the system is operated with a suitable submersible bell instead of a bubbler system, it is advisable that the following be performed once a year:
 - a) Lower the fluid level below that of the bell, i.e. by activating the sip mode,
 - b) Pull the pneumatic tube together with the wet ball completely out of the fluid and submerge again.
- 4.) Recommended tube Festo PAN 6 x 1

Configuration instructions

The device must be switched to test mode for configuration purposes. This can be achieved by pressing the "TEST" key for 2 seconds. The device indicates that it is in test mode optically, by flashing the green test-LED. The 3 LEDs, N1, P+ and AL, now indicate whether the current fluid level lies above or below the corresponding switching thresholds (LED lights up → indicates that fluid level lies above the configured switching threshold). The thresholds can be set higher or lower by turning the corresponding knobs (higher in a clockwise direction, lower in an anticlockwise direction). After configuring the set point tolerances, exit test mode by pressing the "TEST" key once again. The configured values are now stored. Should the integrated base load change control not work properly, it could be due to the set point for the second pump S2 lying below that of the first pump S1. This can be checked and the problem rectified by entering the test mode after which a RESET is to be carried out, i.e. by turning off the operating voltage.

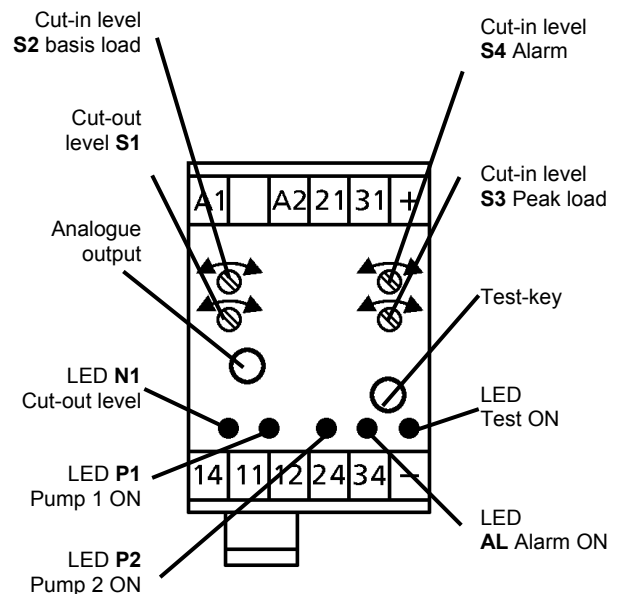

Analogue output and LED assignment in test mode:

a) Cut-out level	Poti S1	LED N1 (green)
b) Basis load level	Poti S2	LED P1 (red)
c) Peak load level	Poti S3	LED P2 (red)
d) Alarm level	Poti S4	LED AL (red)

- Example:**
1. press the "TEST" key for 2 seconds → the device is now in test mode
 2. set the desired shut-off level
 - LED **N1** on → turn the analogue output knob **S1** clockwise until the LED turns off
 - LED **N1** off → turn the analogue output knob **S1** anticlockwise until the LED turns on
 3. adjust the base load level as desired
 - LED **P1** on → turn the analogue output knob **S2** clockwise until the LED turns off
 - LED **P1** off → turn the analogue output knob **S2** anticlockwise until the LED turns on
 4. adjust the peak load level as desired
 - LED **P2** on → turn the analogue output knob **S3** clockwise until the LED turns off
 - LED **P2** off → turn the analogue output knob **S3** anticlockwise until the LED turns on
 5. adjust the alarm level as desired
 - LED **AL** on → turn the analogue output knob **S4** clockwise until the LED turns off
 - LED **AL** off → turn the analogue output knob **S4** anticlockwise until the LED turns on
 6. press the "TEST" key to exit the test mode

Function example 2-pump control

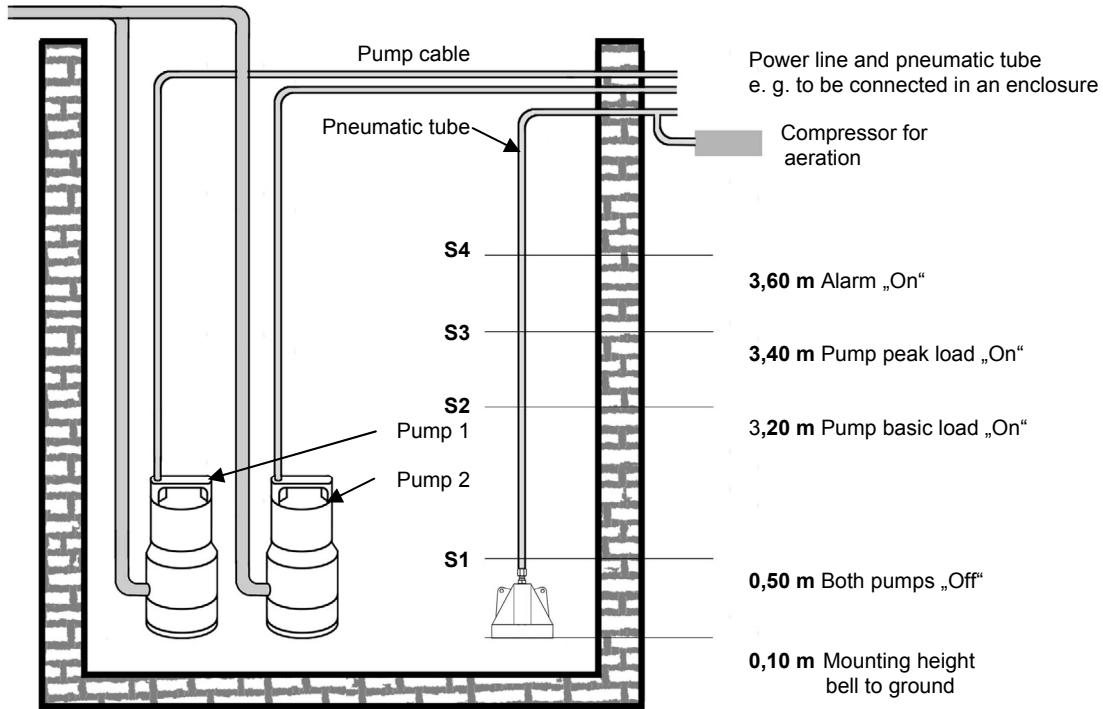

The levels specified here have been chosen arbitrarily and serve as examples (ENP 4,3). The corresponding measurement range and maximum permissible fluid level of the corresponding type ENP should be taken into account when values are set for each respective set point (S1, S2, S3 and S4).

Pump control	ENP 2.3	Measuring range	0,1 – 2 m	max. perm. level	10 m
Pump control	ENP 4.3	Measuring range	0,1 – 4 m	max. perm. level	10 m
Pump control	ENP 10.3	Measuring range	0,1 – 10 m	max. perm. level	20 m

Functional sequence 2-pump control

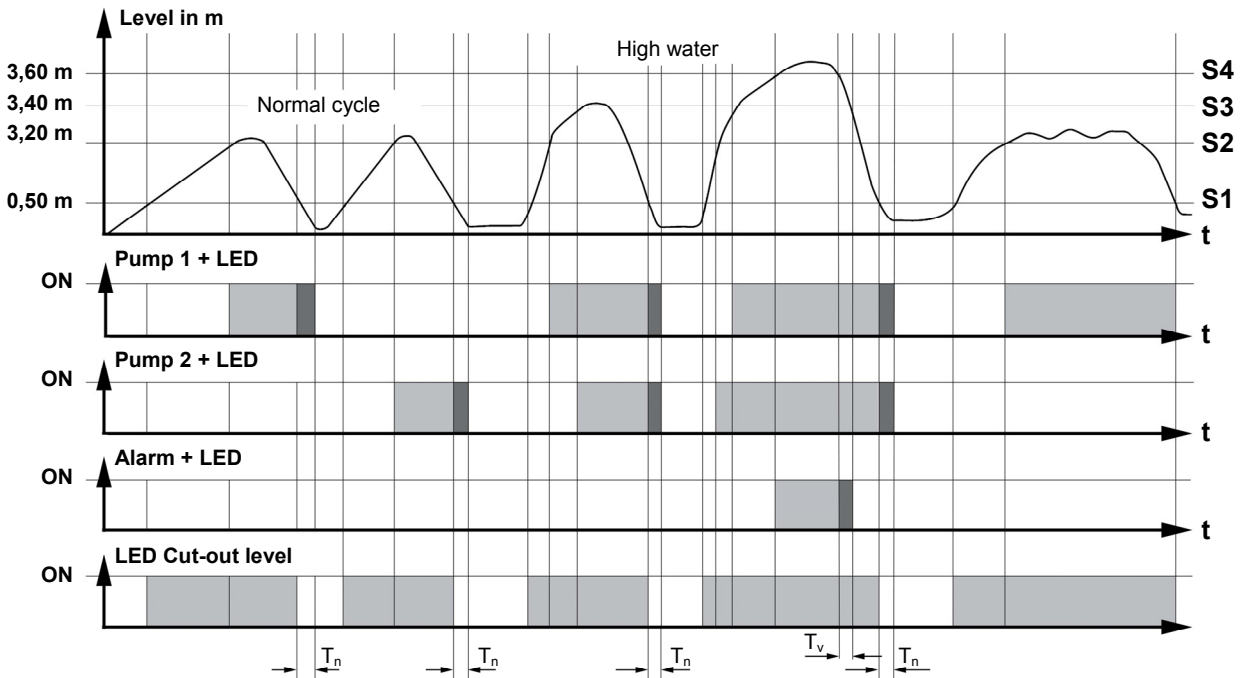

T_v = Switching off delay "Alarm"
 T_n = Follow-up time Pump



Condor Pressure Control GmbH

Warendorfer Straße 47 – 51
 D-59320 Ennigerloh

Phone: +49 (0) 25 87 / 89 - 0
 Telefax: +49 (0) 25 87 / 89 - 140

info@condor-cpc.com
 www.condor-cpc.com